

LAKE JULIETTE SAILING CLUB  
Please Return Undeliverable Items to:  
Editor, 220 Windsor Drive, Warner Robins, GA. 31088

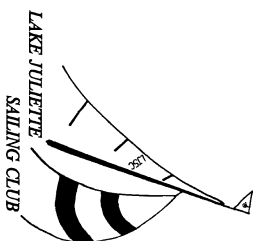

# RUDDER

Volume 7 No. 3

Mar 1997

# JULIETTE

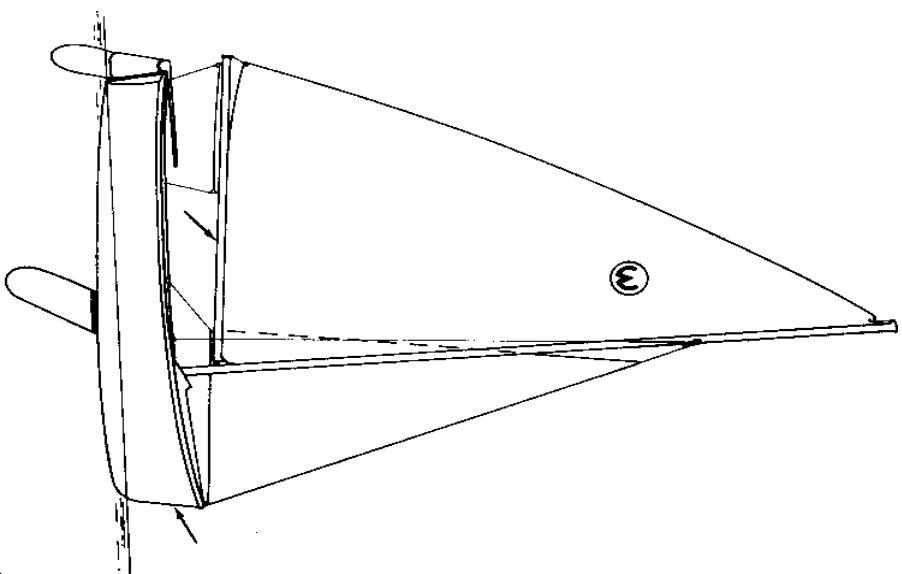



# JULIETTE RUDDER

## OFFICERS

**COMMODORE.....Jan Dillard**  
1431 Beaver Oak Dr. Macon, GA. 477-8408

**VICE COMMODORE.....Ron Falk**  
106 S. Amanda Pl. Warner Robins GA. 31088 - 953-1118

**TREASURER & MEMBERSHIP .....Fred Veator**  
201 Stanley St. Bonaire, GA. 31005 - 922-5277

**RACE COMMITTEE.....George (Boston) Sollows**  
546 Moreland Ave. Macon GA. 31206

**SOCIAL COMMITTEE.....**

**HISTORIAN.....**

**SECRETARY & RUDDER EDITOR.....Bob Horan**  
220 Windsor Dr. Warner Robins GA. 31088 - 929-1377

The RUDDER is the official publication of the Lake Juliette Sailing Club. Statements and opinions appearing herein are those of the authors and do not necessarily represent the group position of the Lake Juliette Sailing Club. The editor reserves the right to edit all material for publication and to publish only that material which is felt to be in the best interest of the Lake Juliette Sailing Club.

1997  
**LAKE JULIETTE SAILING CLUB  
MEMBERSHIP REGISTRATION**

NAME\_\_\_\_\_

ADDRESS\_\_\_\_\_

CITY & ST.\_\_\_\_\_

PHONE\_\_\_\_\_

BOAT 1\_\_\_\_\_

BOAT 2\_\_\_\_\_3\_\_\_\_\_

SPONSOR\_\_\_\_\_

Dues are **\$20** - Payable to: **Fred Veator**

Send to: Bob Horan  
220 Windsor Dr.  
Warner Robins GA. 31088

WHAT I WOULD LIKE TO DO (Pick one or more)

- RACE COMMITTEE ASSISTANCE
- SPECIAL COMMITTEES AS REQUIRED FOR EVENTS
- NEWSLETTER
- CLUB ADMINISTRATION
- OTHER\_\_\_\_\_

EVENTS AND ITEMS I WOULD BE INTERESTED IN:

- FUN RACES
- HANDICAP RACES
- CLASS RACES
- EXCURSIONS
- COOKOUTS
- RAFTUPS
- BEACH PARTIES
- SOCIAL DINNERS

## Sail Parts

For the benefit of those who may have forgotten or maybe even never learned it, I have included a drawing below which defines the parts of the sail on a sailboat. Many of you remember some of them but not all. Of course this is just the basic items and if you really wanted to know every small part of each sail, ask John Drawe or dig through your public library and find a basic sailing and seamanship book.

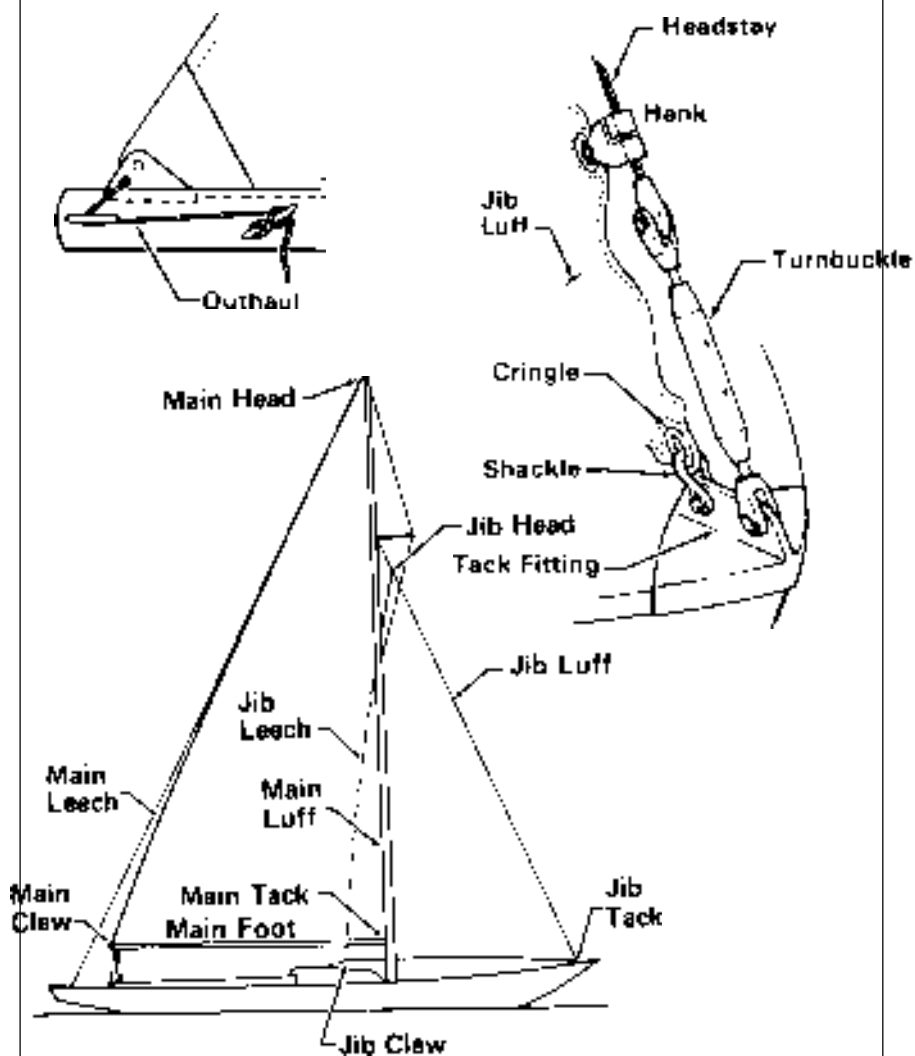

## NOTICES

The March meeting is to be held at Shoney's Restaurant in Byron on Highway 49, near the Peach Outlet. Plan to eat at 7PM with the meeting afterward. We have the meeting room reserved for 30 people and since this is the first time for this restaurant we will be considering it for future meetings. On the agenda for this meeting will include the Cherry Blossom Regatta, Cumberland Island Cruise, future events, and of course the time and place for the meeting in April.

There has been some confusion about how many Cherry Blossom Race days we have had. I thought it was five, George Jester thought it was 3 and some just did not know. I decided to search thru all the old newsletters and find out exactly. The Cherry Blossom Regatta on the 23 of March 1997 will be our 5th. We had the first on Lake Tobesofkee in 1993, then to Lake Juliette in 1994, back to Lake Tobesofkee in 1995 and last year it was held on Lake Juliette again. In 1994 we had more wind than we could handle ( 20 - 30 Knots) and '95 we had almost no wind. Last year was one of our probably our best and this year, who knows? For more information on this event see the flyer which is included in this edition of the JULIETTE RUDDER.

As of press time the Cumberland Island Cruise is still on. Most of the members interested can make it in April, Preferably on the weekend of the 11th thru 14th. If you are interested in this trip even if not that particular weekend, get with me and I will fill you in with some information and maybe hook you up with members who were not able to make it for the April weekend above. Some of us may even want to make a second trip. At any rate if you are interested I can send you a package about the area so you read up on the trip before deciding on a date or itinerary.

## Notices Cont.

If any of you have a dinghy, it might come in handy for this trip because there is some discussion about how we can get ashore on the island. The trip down there from Macon should take about 5 hours. The shortest route is through Eastman, McRae, & Hazelhurst to I95 then down I95. The easiest route from Macon is use I16 to I95, then south on I95. The best launch ramp is debateable but I think I would pick St. Mary's. KingsBay Naval Station has no boat ramp.

A proposal has come up to change the time of the actual meeting start to 7PM with those who want to eat, getting there early. If you were not interested in eating you could arrive order a drink or nothing, but being generous with tips. This would make the meetings end earlier to allow more time for those who have to drive quite a distance home, or who have an early schedule the next morning. This is something we need to discuss, since we all have such a variety of work schedules.

Included on the flyer for the Cherry Blossom Regatta is a proposed schedule for '97. Look it over closely and find all the mistakes I made. Some of the dates picked out may need to be changed so if there are errors or corrections needed let me know. Some of the dates for events late in the season are not available yet and will be added as they become known.

The Club is still without a Social Chairperson. If we expect to be able to coordinate events for this year we need to have someone to handle this job. If any of you can help in this way call Jan and let her know you can help. Mostly it involves coordinating what is going to be brought to the dinners and who is providing what and who is going to do the various jobs for each of our social events like the Commodore's Cookout, and the Golden Open. If you need to know just how hard a job this job is, call Jan LaBeause or Jan Dillard because they have done it in the past.

## Flags

White flag (Up)..... 10 Min. w/single Horn blast  
(Down)..... 6 Min.

Blue Flag (Up)..... 5 Min. w/single Horn blast  
(Down)..... 1 Min.

Red Flag (Up)..... start w/single Horn blast

\* Note for additional class starts, red flag goes down after 4 Min. and back up in one minute for the second and subsequent starts.

## Safety Equipment

Each boat shall have an approved P.F.D. for each person and a throwable flotation device if crew is used. All boats will comply with all safety rules of the Dept. of Natural Resources, Game and Fish Div. of the State of Georgia.

If you have not yet paid your dues for the 1997 sailing season, this is the last pitch. It is only \$20 and look what you get: A great newsletter, an invitation to some of the finest sailing events in the area, the latest information on who is doing what and where they are doing it, and the opportunity to rub elbows with some of Middle Georgia's finest people.

Make out the check of \$20 to Fred Veator and send it in with your 97 registration to Bob Horan or bring it to the March meeting. This is last newsletter of 1997 for those who do not sign up for 97.

# Sailing Instructions

Lake Juliette Sailing Club

## 1997

- It shall be the sole responsibility of each Skipper to decide whether or not to start or to continue to race.
- All racing rules commence at the five minute starting signal. this includes the use of motors and paddles. Rules of the road are always in effect.
- Early starts will require recrossing the starting line. Going around the pin or committee boat and recrossing the line will do but you may not cause another boat to alter course in doing so. The committee boat may inform you as to an early start infraction but is not always able to do so.
- Boats on Starboard tack have the right of way.
- Any intentional collision will disqualify the offending boat from the race and possibly the day or series. If unintended the offending skipper could be disqualified pending a mandatory protest evaluation.
- Any action justifying a protest against a competitor must be remedied by the offending skipper doing a 360 degree turn as soon as possible without causing other boats to alter course.
- Yachts shall clear the finish area upon completion of racing and the first boat over on the last race of the day helps to pick up race markers.

### Time Limit

45 minutes to the first mark; 2 hours for the race  
Subject to the discretion of the RC Boat

## Racing Corner

By Boston

Welcome to the 97 Sailing season racing. We are kicking off the 97 racing season with the 97 Cherry Blossom Regatta. Once again to be held at Lake Juliette on March 23rd. The point used for camping and day visitors will be also open for spectators for our racing even though that area will not open for regular use for some time. Be sure to decorate your boat with pink ribbon and/or flags for the day since there will be media coverage for this event.

The 97 season is going to consist of three separate race days, consisting of a minimum of 3 races each day, wind and weather permitting. Each regatta will have trophies presented for that day only, at the following Club Meeting except for the Cherry Blossom Race. Hopefully this season we will have moderate winds, heavy turnout, & deep water. At the March meeting, I will be accepting volunteers to fill in the TBA race committee boat for the scheduled races which we have not gotten volunteers for.

The tentative LJSC racing days are:

March 23rd. - Cherry Blossom Regatta  
Skipper Meeting 12:00  
Committee Boat - Steve & Jan Dillard

April 26th. - Spring Race (Saturday)  
Skipper Meeting 12:00  
Committee Boat - TBA

June 15th. - Father's Day  
Skippers Meeting 12:00  
Committee Boat - TBA

August 17th - Moonlight cruise  
Sunday race

# Proposed 97 Schedule

## Mar

- 18 Meeting - Byron - Shoney's Restaurant
- 23 Cherry Blossom Regatta

## Apr

- 12-14 Cumberland Island Cruise
- 22 Meeting - Macon
- 26 Spring Race (Saturday)

## May

- 3-4 Mug Race
- 18 Sinclair Regatta (One Day- Saturday)
- 20 Meeting - Warner Robins
- 24-26 Memorial Weekend Cruise

## Jun

- 15 Father's Day Race
- 17 Meeting - Macon

## July

- 4-6 Charleston Harbor Cruise
- 15 Meeting - Warner Robins/Byron
- 27 Treasure Hunt and Commodore's Cookout

## Aug

- 16,17 Moonlight Sail / Sunday Race
- 19 Meeting - Macon

## Sep

- 16 Meeting - Warner Robins/Byron
- 30-1 Labor Day Weekend Regatta/Cruise - Augusta Sailing Club

---

Halloween Regatta - Augusta Sailing Club

Golden Open - OSYC

---

## Dec

- 5-7 Sailfest - Sanford, Fl.

